



RGD Series



Models:

C1RGD03-D230AC
C1RGD10-D230AC
MMRGD03-D230AC
MMRGD03-D230AC-PCM
MMRGD10-D230AC
MMRGD10-D230AC-PCM

Digital SCR Regen,
Variable-Speed DC Drives

User's Manual

Copyright © 2002 by
Minarik Corporation

All rights reserved. No part of this manual may be reproduced or transmitted in any form without written permission from Minarik Corporation. The information and technical data in this manual are subject to change without notice. Minarik Corporation and its Divisions make no warranty of any kind with respect to this material, including, but not limited to, the implied warranties of its merchantability and fitness for a given purpose. Minarik Corporation and its Divisions assume no responsibility for any errors that may appear in this manual and make no commitment to update or to keep current the information in this manual.

Printed in the United States of America.

Safety Warnings



- This symbol  denotes an important safety tip or warning. **Please read these instructions carefully** before performing any of the procedures contained in this manual.
- **DO NOT INSTALL, REMOVE, OR REWIRE THIS EQUIPMENT WITH POWER APPLIED.** Have a qualified electrical technician install, adjust and service this equipment. Follow the National Electrical Code and all other applicable electrical and safety codes, including the provisions of the Occupational Safety and Health Act (OSHA), when installing equipment.
- Reduce the chance of an electrical fire, shock, or explosion by proper grounding, over-current protection, thermal protection, and enclosure. Follow sound maintenance procedures.



It is possible for a drive to run at full speed as a result of a component failure. Minarik strongly recommends the installation of a master switch in the main power input to stop the drive in an emergency.

Circuit potentials are at 115 VAC or 230 VAC above earth ground. Avoid direct contact with the printed circuit board or with circuit elements to prevent the risk of serious injury or fatality. Use a non-metallic screwdriver for adjusting the calibration trimpots. Use approved personal protective equipment and insulated tools if working on this drive with power applied.

Table of Contents

Safety Warnings	i
Regenerative Drives	vii
Specifications	1
Dimensions	2
Installation	7
Drive mounting (General)	7
Drive mounting (MMRGD)	7
Drive mounting (C1RGD)	8
Wiring	10
Shielding guidelines	11
Heat sinking	12
Line fusing	12
Speed adjust potentiometer installation	14
Speed adjust potentiometer connections	15
MMRGD	15
CIRGD	15
Connections	17
MMRGD	17
Motor	17
Power input	18
Line fuse	18
C1RGD	21
Motor	21
Power input	21
Selector switches	24
Voltage selector (SW501, SW502)	24
Feedback selector (SW503)	24
Armature voltage selector (SW504)	24

Voltage follower	27
MMRGD	27
C1RGD	27
Operation	28
Before applying power	28
MMRGD drive startup	29
To start the drive	29
MMRGD drive shutdown	29
C1RGD drive startup	30
To start the drive	30
C1RGD drive shutdown	30
Starting and Stopping Methods	31
Line starting and stopping	31
Decelerate to a stop (MMRGD)	32
Regenerative braking (MMRGD)	33
INHIBIT mode (MMRGD)	34
Disable/Enable terminals (MMRGD)	35
Regenerative braking (C1RGD)	36
Diagnostic LEDs	37
Calibration	40
Minimum Speed (MIN SPD)	42
Maximum Speed (MAX SPD)	42
Forward Torque (FWD TQ)	43
Reverse Torque (REV TQ)	44
IR Compensation (IR COMP)	46
Forward Acceleration (FWD ACC)	47
Reverse Acceleration (REV ACC)	47
Tachogenerator (TACH)	48
Signal Adjustment (SIGNAL ADJUST)	49
Application Notes	51
Connection to DLC600	51
Optional speed adjust potentiometer connections to MMRGD series drives	52
Independent Adjustable Speeds (Forward Direction Only)	53

Table of Contents (cont.)

Independent Forward and Reverse Speeds	54
Independent Forward and Reverse Speeds With FWD-STOP-REV Switch	55
Troubleshooting	56
Before troubleshooting	56
Replacement Parts	59
Unconditional Warranty	Inside Back Cover

Tables

Table 1. Recommended Line Fuse Sizes	13
Table 2. Replacement Parts	59

Illustrations

Figure 1. Four-Quadrant Operation	viii
Figure 2. MMRGD Dimensions	2
Figure 3. MMRGD Dimensions with drive mounted on 223-0159 heat sink	3
Figure 4. MMRGD-PCM Dimensions	4
Figure 5. C1RGD Dimensions	5
Figure 6. Heat Sink Dimensions	6
Figure 7. C1RGD Mounting Hole Locations	9
Figure 8. MMRGD Speed Adjust Potentiometer	14
Figure 9. MMRGD Speed Adjust Potentiometer Connections	16
Figure 10. MMRGD Power, Motor and Fuse Connections (Bottom Board)	19
Figure 11. MMRGD-PCM Connections	20
Figure 12. C1RGD Power and Motor Connections	22
Figure 13. C1RGD Front Panel Switch Connections	23
Figure 14. MMRGD Selector Switch Locations	25
Figure 15. C1RGD Selector Switch Locations	26
Figure 16. MMRGD Voltage Follower Connection	27
Figure 17. RUN/STOP Switch	32
Figure 18. MMRGD Regenerative Brake Terminals With Optional RUN/BRAKE Switch	33
Figure 19. Inhibit Terminals Showing Optional Switch Installation	34
Figure 20. Enable/Disable Terminals Showing Optional Switch Installation	35
Figure 21. C1RGD Front Panel Switch Layout	36
Figure 22. MMRGD Diagnostic LED Location	38
Figure 23. C1RGD Diagnostic LED Location	39

Illustrations (cont.)

Figure 24. Calibration Trimpot Layout	41
Figure 25. Recommended IR COMP, REVERSE TORQUE and FORWARD TORQUE Settings	50
Figure 26. MMRGD Connection to DLC600	51
Figure 27. Forward-Reverse Switch	52
Figure 28. Forward-Stop-Reverse Switch	52
Figure 29. Independent Adjustable Speeds (Forward Direction)	53
Figure 30. Independent Forward and Reverse Speeds	54
Figure 31. Independent Forward and Reverse Speeds with a Forward-Stop-Reverse Switch	55

Regenerative Drives

Most non-regenerative variable-speed DC drives control current flow to a motor in one direction. The direction of current flow is the same direction as the motor rotation. Non-regenerative drives operate in Quadrant 1 and Quadrant 3 if the drive is reversible (see Figure 1, page viii). Motors must stop before reversing direction. Unless dynamic braking is used, non-regenerative drives cannot decelerate a load faster than coasting to a lower speed.

Regenerative drives operate in two additional quadrants: Quadrant 2 and Quadrant 4. In these quadrants, motor torque is in the opposite direction of motor rotation.

Regenerative drives can reverse a motor without contactors, switches, brake resistors and inhibit plugs. They can also control an overhauling load and decelerate a load faster than it would take to coast to a lower speed.

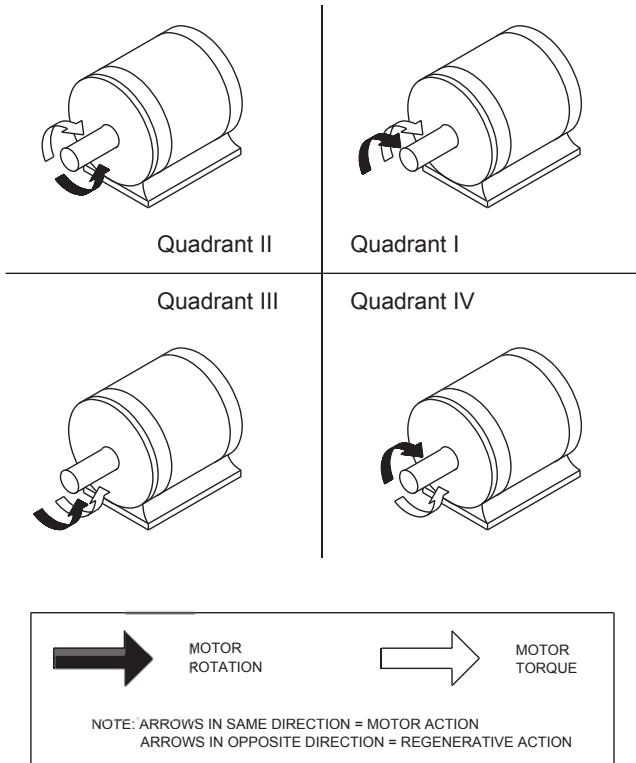

Figure 1. Four-Quadrant Operation

Specifications

Model	Maximum Armature Current (DC Amps)	Horsepower Range (115 VAC Input)	Horsepower Range (230 VAC Input)	Armature Voltage Range † (DC Volts)
C1RGD03-D230AC	3.0	1/20 – 1/4	1/10 – 1/2	0 – 180
C1RGD10-D230AC*	5.0	1/4 – 1/2	1/2 – 1	0 – 180
MMRGD03-D230AC	3.0	1/10 – 1/4	1/10 – 1/2	0 – 180
MMRGD03-D230AC-PCM	3.0	1/10 – 1/4	1/10 – 1/2	0 – 180
MMRGD10-D230AC**	5.0	1/4 – 1/2	1/2 – 1	0 – 180
MMRGD10-D230AC-PCM**	5.0	1/4 – 1/2	1/2 – 1	0 – 180

† With 230 VAC applied; 0 – 90 VDC with 115 VAC applied.

* When mounted to heat sink kit part number 223–0355, the maximum armature current increases to 10 ADC and maximum horsepower increases to 1 HP (115 VAC input) or 2 HP (230 VAC input).

** When mounted to heat sink kit part number 223–0159, the maximum armature current increases to 10 ADC and maximum horsepower increases to 1 HP (115 VAC input) or 2 HP (230 VAC input).

AC Line Voltage	115/230 VAC ±10%, 50/60 Hz, single phase
Form Factor	1.37 at base speed
Acceleration Time Range	0.5 – 6 seconds
Deceleration Time Range	0.5 – 6 seconds
Analog Input Voltage Range (signal must be isolated; S0 to S2)	-10 VDC to +10VDC
PCM Model Analog Input Voltage Range	0 - 10 VDC
Input Impedance (S0 to S2)	30 kΩ
PCM Model Input Impedance (POS to NEG)	1 kΩ
Load Regulation	1% base speed
Vibration	0.5G max. (20–50 Hz)
Ambient Temperature Range (chassis drives)	10°C–55°C
Ambient Temperature Range (enclosed drives)	10°C–40°C
Weight	1.1 lb

Dimensions

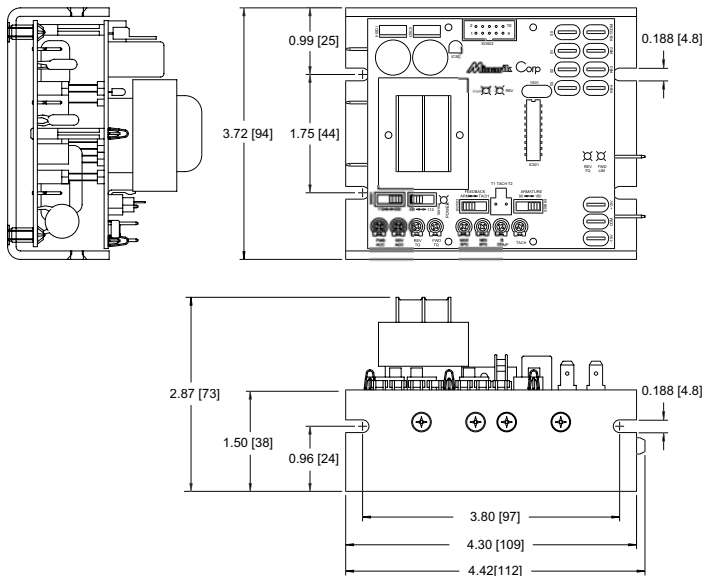

ALL DIMENSIONS IN INCHES [MILLIMETERS]

Figure 2. MMRGD Dimensions

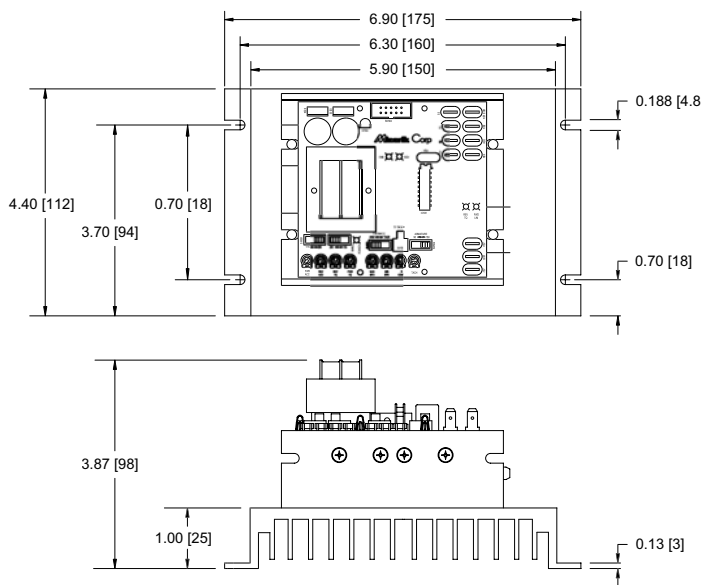

ALL DIMENSIONS IN INCHES [MILLIMETERS]

Figure 3. MMRGD Dimensions with drive mounted on 223-0159 heat sink

4 Dimensions

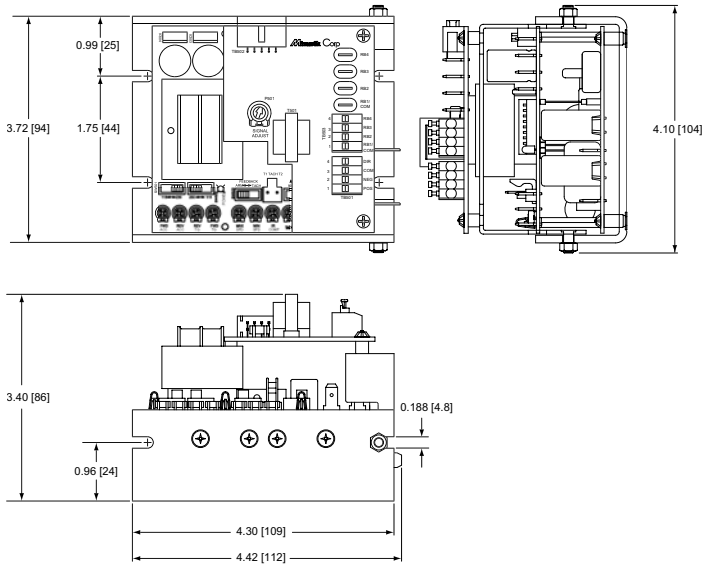

ALL DIMENSIONS IN INCHES [MILLIMETERS]

Figure 4. MMRGD-PCM Dimensions

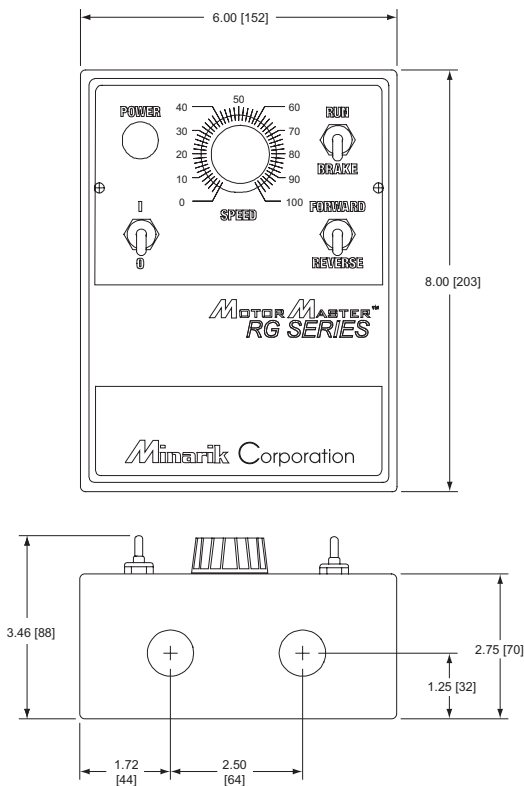

ALL DIMENSIONS IN INCHES [MILLIMETERS]

Figure 5. C1RGD Dimensions

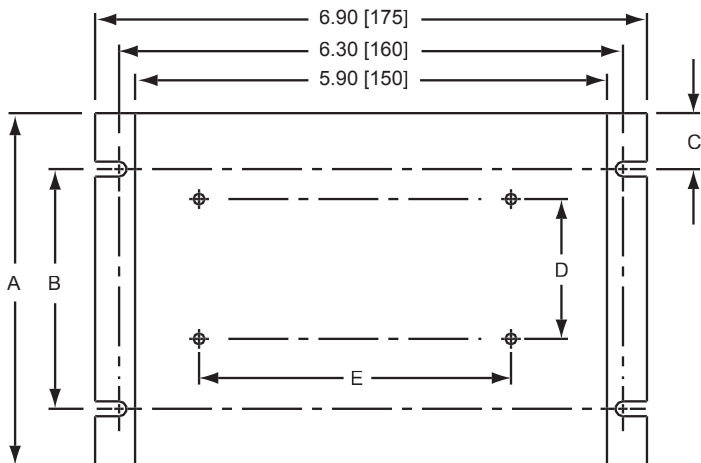

MOUNTING SLOTS 0.19 X 0.34 [5 X 9]
 ALL DIMENSIONS IN INCHES [MILLIMETERS]

PART NO.	DIM "A"	DIM "B"	DIM "C"	DIM "D"	DIM "E"
223-0159	4.40 [112]	3.00 [76]	0.7 [18]	1.75 [44]	3.90 [100]
223-0174	7.78 [198]	6.00 [152]	0.89 [23]	6.00 [152]	5.35 [136]

Heat sinks sold separately.

Figure 6. Heat Sink Dimensions

Installation

Drive mounting (General)

- Drive components are sensitive to electrostatic fields. Avoid direct contact with the circuit board.
- Protect the drive from dirt, moisture, and accidental contact.
- Provide sufficient room for access to the terminal block and calibration trim pots.
- Mount the drive away from heat sources. Operate the drive within the specified ambient operating temperature range.
- Prevent loose connections by avoiding excessive vibration of the drive.

Drive mounting (MMRGD)

- Mount the drive with its board in either a horizontal or vertical plane. Eight (8) 0.188 inch [4.8 mm] wide slots in the chassis accept #8 pan head screws. Fasten either the large base or the narrow flange of the chassis to the subplate.
- The drive must be earth grounded for noise suppression. Connect earth ground to the earth ground terminal on the drive's bottom board (see Figure 10, page 19, for location).

Drive mounting (C1RGD)

C1RGD drives come with two (2) 0.88 inch [22 mm] conduit holes at the bottom of the case. Units without a heatsink (5 ADC or below) may be vertically wall mounted or horizontally bench mounted using the three keyholes on the back of the case. See Figure 7 (page 9) for mounting hole locations of C1RGD controls without a heatsink. For mounting of C1RGD controls with a heatsink (over 5 ADC) the four (4) 0.188 inch [4.8 mm] wide slots in the heatsink. The slots accept #8 pan head screws. See Figure 6 (page 6) for mounting slot locations.

1. For access to the keyholes and the terminal strip, remove the two screws from the front of the case by turning them counterclockwise. Grasp the front cover and lift it straight out.
2. Install the mounting screws in the three keyholes.
3. Install conduit hardware through the conduit holes at the bottom of the case. Connect external wiring to the terminal block.
4. Reinstall the front cover. Avoid pinching any wires between the front cover and the case.
5. Replace the two screws to the front cover. Turn the screws clockwise to tighten.

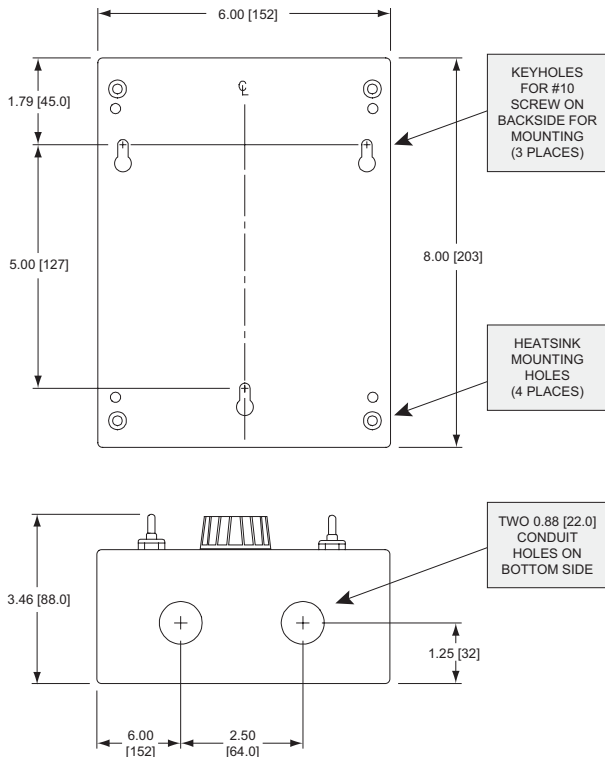

ALL MEASUREMENTS IN INCHES [MILLIMETERS]

Figure 7. C1RGD Mounting Hole Locations

Wiring



Warning



Do not install, remove, or rewire this equipment with power applied. Failure to heed this warning may result in fire, explosion, or serious injury.

Circuit potentials are at 115 or 230 VAC above ground. To prevent the risk of injury or fatality, avoid direct contact with the printed circuit board or with circuit elements.

Do not disconnect any of the motor leads from the drive unless power is removed or the drive is disabled. Opening any one motor lead may destroy the drive.

- Use 18 AWG wire for speed adjust potentiometer wiring. Use 16 AWG wire for AC line (L1, L2) and motor (A1, A2) wiring.

Shielding guidelines



Warning

Under no circumstances should power and logic leads be bundled together. Induced voltage can cause unpredictable behavior in any electronic device, including motor controls.

As a general rule, Minarik recommends shielding of all conductors.

If it is not practical to shield power conductors, Minarik recommends shielding all logic-level leads. If shielding of logic leads is not practical, the user should twist all logic leads with themselves to minimize induced noise.

It may be necessary to earth ground the shielded cable. If noise is produced by devices other than the drive, ground the shield at the drive end. If noise is generated by a device on the drive, ground the shield at the end away from the drive. Do not ground both ends of the shield.

If the drive continues to pick up noise after grounding the shield, it may be necessary to add AC line filtering devices, or to mount the drive in a less noisy environment.

Logic wires from other input devices, such as motion controllers and PLL velocity controllers, must be separated from power lines in the same manner as the logic I/O on this drive.

Heat sinking

MMRGD10 series drives require heat sink kit 223-0159 when the continuous armature current is above 5 ADC. C1RGD10 series drives require heat sink kit 223-0355 when the continuous armature current is above 5 ADC. MMRGD03 and C1RGD03 series drives do not require an additional heat sink. Refer to Figure 6 (page 6) for C1RGD heat sink mounting hole locations.

Use a thermally conductive heat sink compound (such as Dow Corning® 340 Heat Sink compound) between the drive chassis and the heat sink surface for optimum heat transfer.

Line fusing

Minarik drives require fuses for protection. Use fast acting fuses rated for 250 VAC or higher and approximately 150% of the maximum armature current. Install a fuse on L1 if the input is 115 VAC. Fuse both L1 and L2 when the line voltage is 230 VAC. The C1RGD drive is pre-wired with two internal 5A fuses (for C1RGD03 drives), or two 15A fuses (for C1RGD10 drives).

Table 1 lists the recommended line fuse sizes.

Table 1. Recommended Line Fuse Sizes

90 VDC Motor Horsepower	180 VDC Motor Horsepower	Max. DC Armature Current (amps)	AC Line Fuse Size (amps)
1/20	1/10	0.5	3
1/15	1/8	0.8	3
1/8	1/4	1.5	5
1/6	1/3	1.7	5
1/4	1/2	2.5	8
1/3	3/4	3.5	8
1/2	1	5.0	10
3/4	1 1/2	7.5	15
1	2	10	20

Minarik Corporation offers two fuse kits: part number 050-0069 (3-8A Fuse Kit) and 050-0073 (5-20A Fuse Kit). Both fuse kits include a 63mA pico fuse (part number 050-0081), which protects the transformer and logic.

Speed adjust potentiometer installation



Warning

Be sure that the potentiometer tabs do not make contact with the potentiometer enclosure. Grounding the input will cause damage to the drive.

Mount the speed adjust potentiometer through a 0.38 in. (10 mm) hole with the hardware provided (Figure 8). Inst all the circular insulating disk between the panel and the 10K ohm speed adjust potentiometer.

Twist the speed adjust potentiometer wire to avoid picking up unwanted electrical noise. If speed adjust potentiometer wires are longer than 18 in. (457 mm), use shielded cable. Keep speed adjust potentiometer wires separate from power leads (L1, L2, A1, A2).

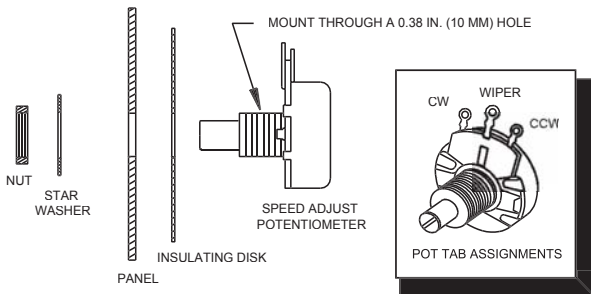

Figure 8. MMRGD Speed Adjust Potentiometer

Speed adjust potentiometer connections

MMRGD

The motor can operate in one direction (unidirectional) or two directions (bidirectional) depending on how the speed adjust potentiometer is connected to the drive.

Connect the speed adjust potentiometer as shown in Figure 9(a) on page 16 for bidirectional operation. The motor should stop when the wiper is in the center position. Turning the wiper CW from center causes the motor to rotate in one direction, while turning the wiper CCW from center causes rotation in the opposite direction.

Connect the speed adjust potentiometer as shown in Figure 9(b) on page 16 for unidirectional operation in the forward direction.

Connect the speed adjust potentiometer as shown in Figure 9(c) on page 16 for unidirectional operation in the reverse direction.

Refer to the Application Notes for additional speed adjust potentiometer connections.

CIRGD

The speed adjust potentiometer is prewired for bidirectional operation on C1RGD series drives. Reversing is accomplished by setting the FWD/REV switch on the front panel to the desired direction.

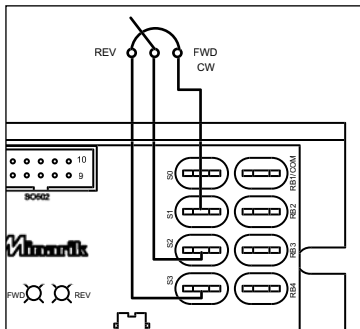

(a) Bidirectional Operation

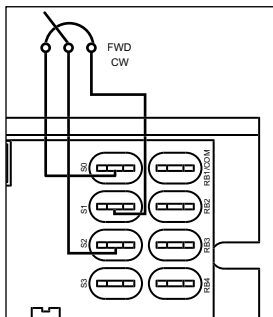

**(b) Unidirectional Operation,
Forward Direction**

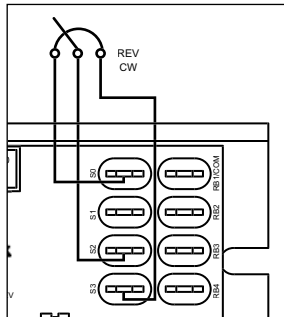

**(c) Unidirectional Operation,
Reverse Direction**

Figure 9. MMRGD Speed Adjust Potentiometer Connections

Connections



Warning

Do not connect this equipment with power applied.

Failure to heed this directive may result in fire or serious injury.

When installing an MMRGD series drive, Minarik strongly recommends the installation of a master power switch in the voltage input line, as shown in Figure 10, page 19.

The switch contacts should be rated at a minimum of 200% of motor nameplate current and 250 volts.

MMRGD

Connect the power input leads, an external line fuse and a DC motor to TB501 on the drive's printed circuit board (PCB) as shown in Figure 10, page 19.

Motor

Minarik drives supply motor voltage from A1 and A2 terminals. It is assumed throughout this manual that, when A1 is positive with respect to A2, the motor will rotate clockwise (CW) while looking at the output shaft protruding from the front of the motor. If this is opposite of the desired rotation, simply reverse the wiring of A1 and A2 with each other.

Connect a DC motor to PCB terminals A1 and A2 as shown in Figure 10, page 19. Ensure that the motor voltage rating is consistent with the drive's output voltage.

Power input

Connect the AC line power leads to terminals L1 and L2, or to a double-throw, single-pole master power switch (recommended).

Line fuse

Wire an external line fuse between the stop switch (if installed) and the L1 terminal on the PCB. An additional line fuse should be installed on L2 if the input voltage is 230 VAC. The line fuse(s) should be rated at 250 volts and 150 - 200% of maximum motor nameplate current. Refer to the line fuse chart on page 13 for fuse ratings.

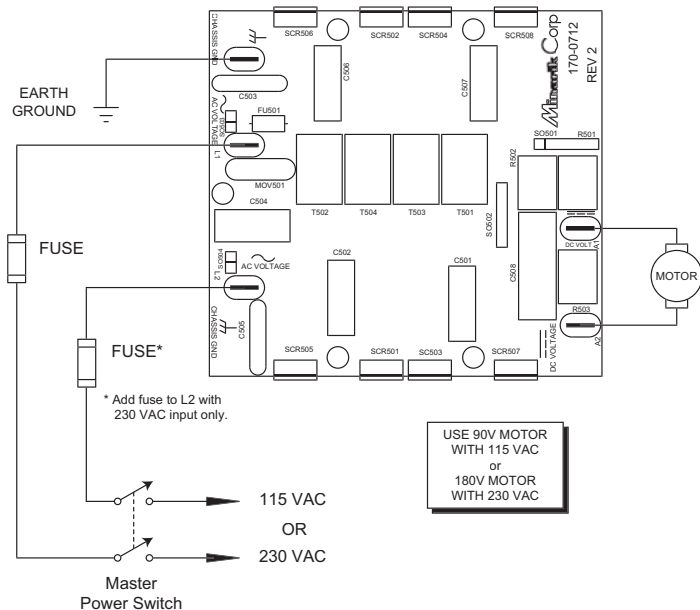

Figure 10. MMRGD Power, Motor and Fuse Connections (Bottom Board)

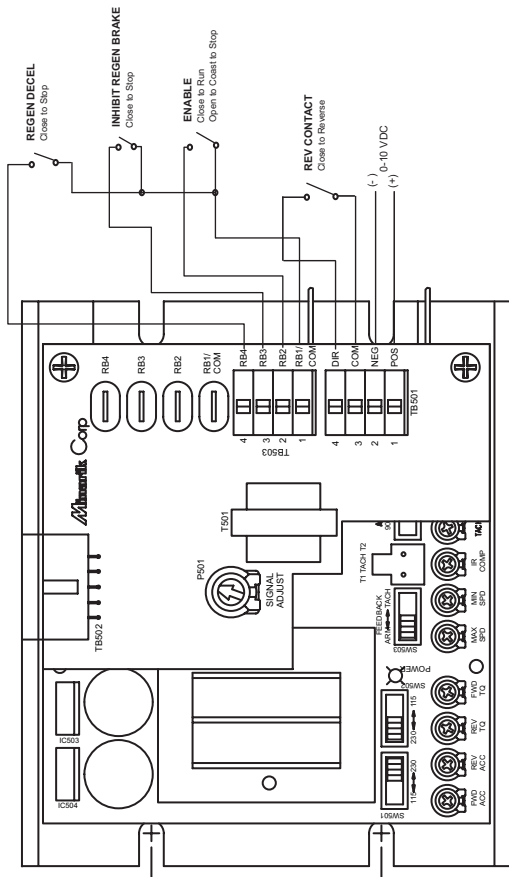

Figure 11. MMRGD-PCM Connections

C1RGD

Connect the power input leads, an external line fuse and a DC motor to TB501 on the drive's printed circuit board (PCB) as shown in Figure 12, page 22.

Motor

Minarik drives supply motor voltage from A1 and A2 terminals. It is assumed throughout this manual that, when A1 is positive with respect to A2, the motor will rotate clockwise (CW) while looking at the output shaft protruding from the front of the motor. If this is opposite of the desired rotation, simply reverse the wiring of A1 and A2 with each other.

Connect a DC motor to TB501 terminals A1 and A2 as shown in Figure 12, page 22. **Ensure that the motor voltage rating is consistent with the drive's output voltage.**

Power input

Connect the AC line power leads to TB501 terminals L1 and L2, or to a double-throw, single-pole master power switch (recommended).

TB501

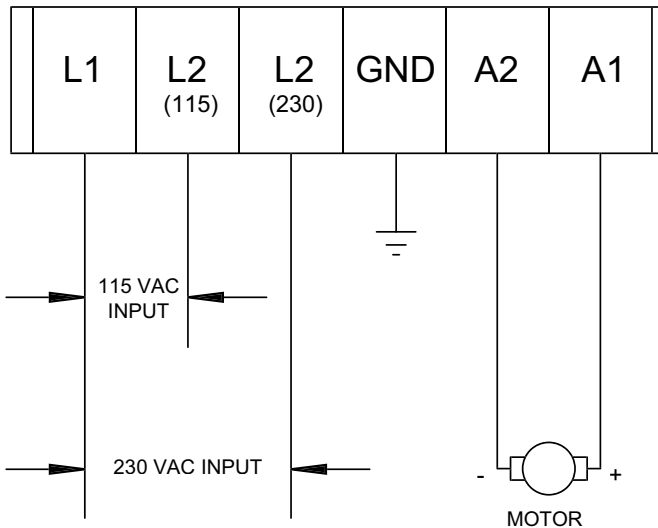
**Figure 12. C1RGD Power and Motor Connections**

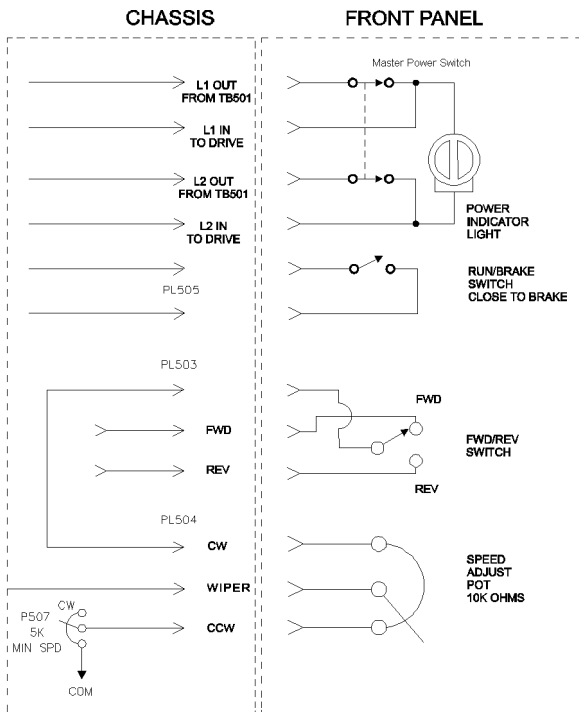

Figure 13. C1RGD Front Panel Switch Connections

Selector switches

Figure 14, page 25 shows the location of the voltage, feedback and armature voltage selector switches on MMRGD series drives. Figure 15, page 26 shows the location of these switches on C1RGD series drives. Ensure that these switches are in the proper positions for your application prior to applying power .

Voltage selector (SW501, SW502)

Set these switches to 115 or 230, as your application requires. It is extremely important that these switches are set properly before applying power or the motor may be damaged as a result.

Feedback selector (SW503)

Set this switch to ARM if using the motor armature output for feedback. Set to TACH if using a tachogenerator for feedback.

Armature voltage selector (SW504)

Set this switch to 90V or 180V , as your application requires. It is extremely important that this switch is set properly before applying power or the motor may be damaged as a result.

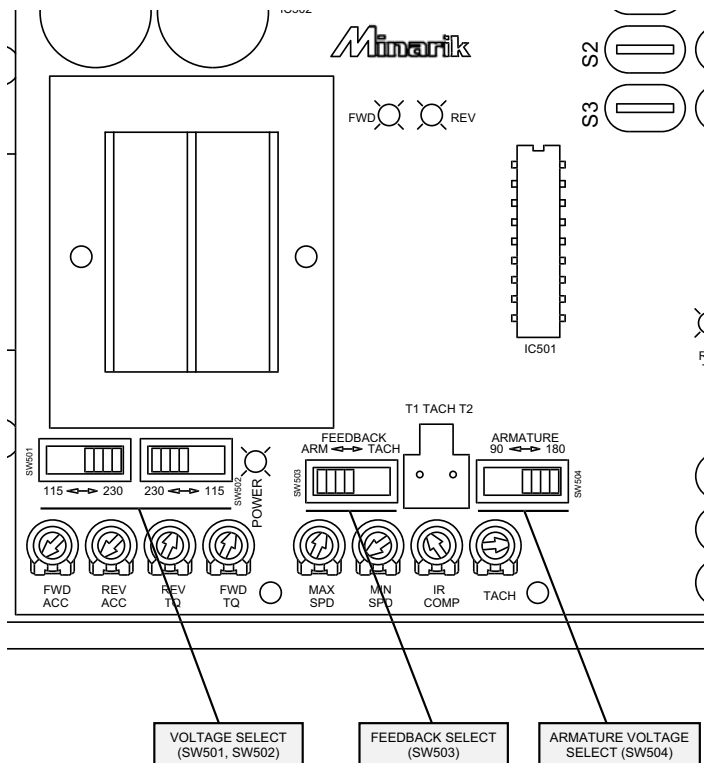

Figure 14. MMRGD Selector Switch Locations

Voltage follower

MMRGD

The drive may be wired to follow a floating (isolated) 0 to ± 10 VDC signal that is isolated from earth ground instead of using a speed adjust potentiometer. Connect the signal input to S2 and the signal common to S0 (see Figure 16).

C1RGD

C1RGD series drives cannot be configured as a volt age follower.

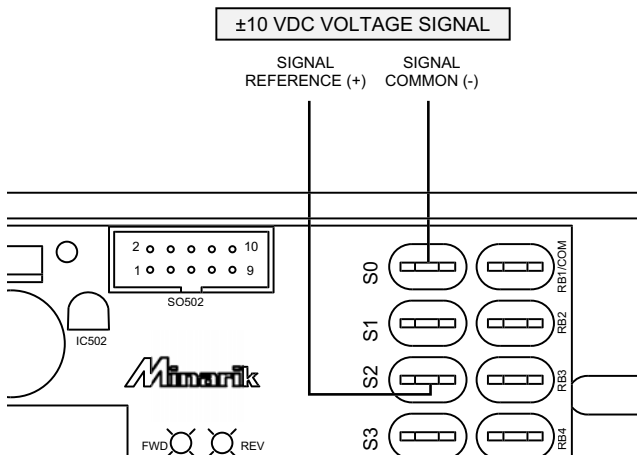

Figure 16. MMRGD Voltage Follower Connection

Operation



Warning

Dangerous voltages exist on the drive when it is powered. BE ALERT. High voltages can cause serious or fatal injury. For your safety, use personal protective equipment (PPE) when operating this drive.

Before applying power

- Verify that no conductive material is present on the printed circuit board.
- Verify that the AC supply is properly balanced.
- Check that the input power, armature voltage and feedback selector switches are set to the correct position. See Figures 14 and 15, pages 25 and 26 for selector switch locations.

MMRGD drive startup

To start the drive

1. **Bidirectional Operation** - set the signal input voltage or speed adjust potentiometer to zero (center position).

Unidirectional operation - set the signal input voltage or speed adjust potentiometer to zero (full CCW).

2. Apply AC line voltage.

3. **Bidirectional operation** - slowly turn the speed adjust potentiometer until the desired speed is reached. Rotate the potentiometer clockwise to rotate the motor forward or counterclockwise to rotate the motor in the reverse direction. If a voltage signal is used, increase or decrease to your desired voltage.

Unidirectional operation - slowly turn the speed adjust potentiometer CW until the desired speed is reached. If a voltage signal is used, increase or decrease to your desired voltage.

MMRGD drive shutdown

To decelerate the motor from set speed to a stop, set the speed adjust potentiometer to zero speed. To coast the motor from set speed to a stop, remove AC line voltage from the drive.

C1RGD drive startup

To start the drive

1. Turn the speed adjust potentiometer full CCW.
2. Set the FWD/REV switch to the desired direction.
3. Set the RUN/BRK switch to BRK.
4. Set the POWER switch to ON (up). The POWER ON indicator will light.
5. Set the RUN/BRK switch to RUN. Slowly turn the speed adjust potentiometer clockwise until the desired speed is reached.

C1RGD drive shutdown

To quickly decelerate the motor from set speed to a stop, set the RUN/BRK switch to BRK. To coast the motor from set speed to a stop, set the POWER switch to OFF (down).

Starting and Stopping Methods



Warning

Decelerating to minimum speed, regenerative braking, or coasting to a stop is recommended for frequent starts and stops. Do not use any of these methods for emergency stopping. They may not stop a drive that is malfunctioning. Removing AC line power (both L1 and L2) is the only acceptable method for emergency stopping.

For this reason, **Minarik strongly recommends installing an emergency stop switch on both the L1 and L2 inputs** (see *Connections section, page 17*).

Line starting and stopping

When AC line voltage is applied to the drive, the motor accelerates to the set speed. When AC line voltage is removed, the motor coasts to a stop. Line stopping (removing AC line voltage) is recommended for stopping in emergency situations only. It is not recommended for frequent starting and stopping.

Decelerate to a stop (MMRGD)

The RUN/STOP switch shown in Figure 17 may be used to decelerate a motor to a stop. The REV ACC trimpot setting determines the rate at which the drive decelerates. Set the switch to the RUN position to accelerate the motor to set speed at a rate controlled by the FWD ACC trimpot.

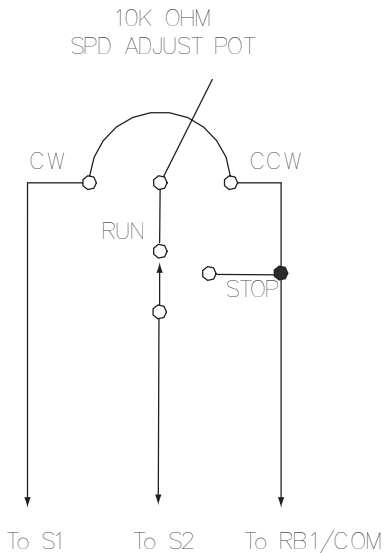
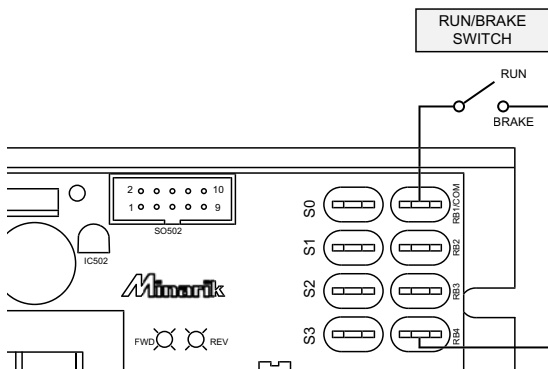

Figure 17. RUN/STOP Switch

Regenerative braking (MMRGD)

Short RB4 to RB1/COM to regeneratively brake the motor, or connect a single-pole, single-throw switch from RB4 to RB1/COM as shown in Figure 18. Closing the switch will cause the motor to regeneratively brake at a rate controlled by the REV ACC trimpot. Opening the switch will cause the motor to accelerate at a rate controlled by the FWD ACC trimpot.

Twist logic wires and separate them from power-carrying wires or sources of electrical noise. Use shielded cable if the inhibit wires are longer than 18 in. (46 cm). If shielded cable is used, ground only one end of the shield to earth ground. Do not ground both ends of the shield.



**Figure 18. MMRGD Regenerative Brake Terminals
With Optional RUN/BRAKE Switch**

INHIBIT mode (MMRGD)

Short RB3 to RB1 to regeneratively inhibit the motor, which will decelerate at a rate controlled by the FWD TQ / REV TQ trimpot settings. Removing the short causes the motor to accelerate to set speed.

An option is to connect a single-pole, single-throw switch between RB3 and RB1. Close the switch to regeneratively brake; open the switch to accelerate to set speed. See Figure 19 for inhibit mode switch connections.

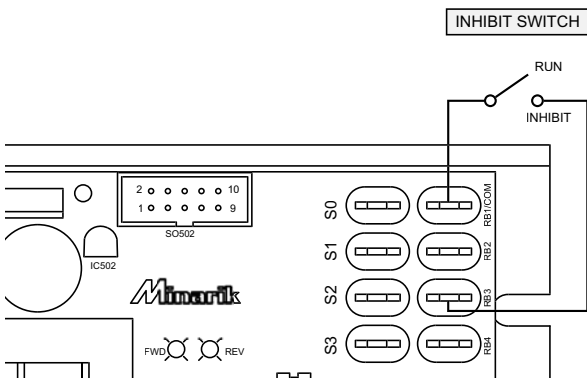

Figure 19. Inhibit Terminals Showing Optional Switch Installation

Disable/Enable terminals (MMRGD)

Each drive is assembled with the DISABLE/ENABLE terminals set for ENABLE (jumper installed between terminals RB1 and RB2). This enables the power section of the drive. These terminals must be connected for the motor to run.

To disable the drive, remove the jumper between RB2 and RB1. The motor will coast to a stop.

An option is to connect a single-pole, single-throw switch between RB2 and RB1 (Figure 20). Close the switch to enable the drive. Open the switch to disable and coast to a stop.

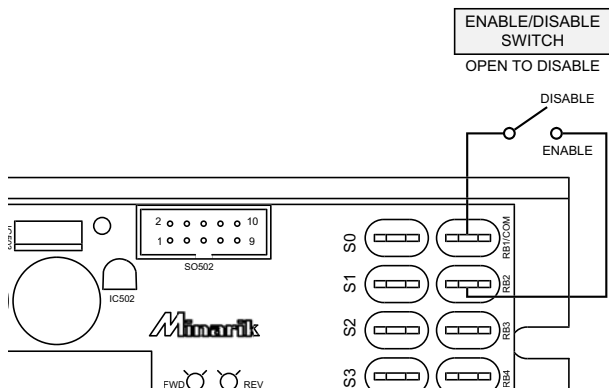

Figure 20. Enable/Disable Terminals Showing Optional Switch Installation

Regenerative braking (C1RGD)

Set the RUN/BRAKE switch on the front p anel to BRAKE in order to decelerate the motor from set speed to a stop using regenerative braking (Figure 21). Set the switch to the RUN position to accelerate the motor to set speed. The rate of acceleration is determined by the FWD ACC trimpot.

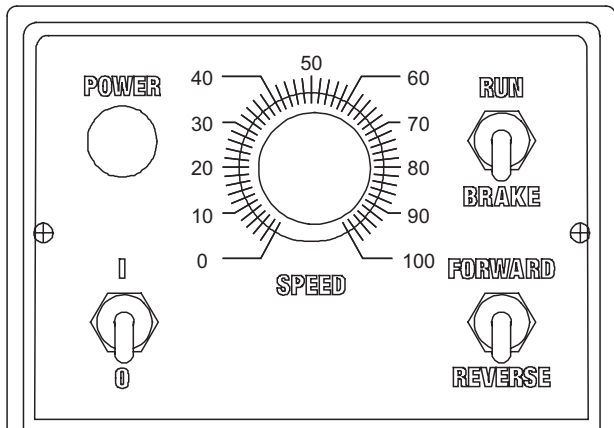

Figure 21. C1RGD Front Panel Switch Layout

Diagnostic LEDs

MMRGD and C1RGD series drives are equipped with diagnostic LEDs. See Figures 22 and 23, (pages 38 and 39) for LED locations.

FWD (Amber)

Indicates that the drive is operating in the forward direction.

REV (Amber)

Indicates that the drive is operating in the reverse direction.

FWD CL (RED)

Indicates drive is in current limit in the forward direction.

REV CL (RED)

Indicates drive is in current limit in the reverse direction.

POWER (GREEN)

Indicates that power is on.

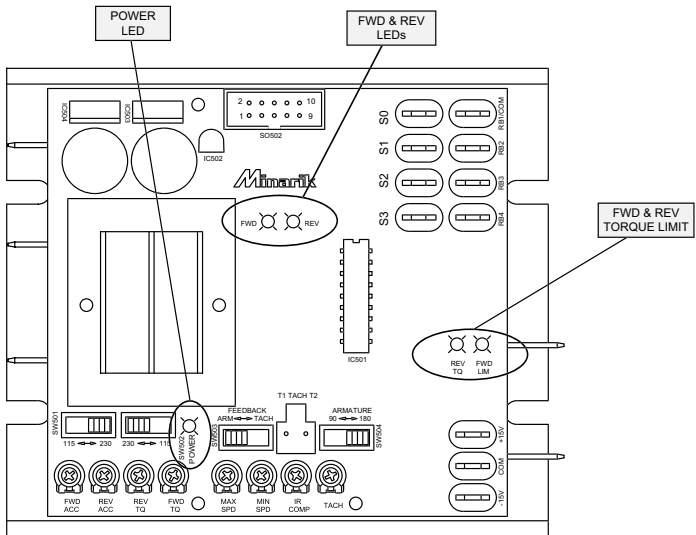

Figure 22. MMRGD Diagnostic LED Location

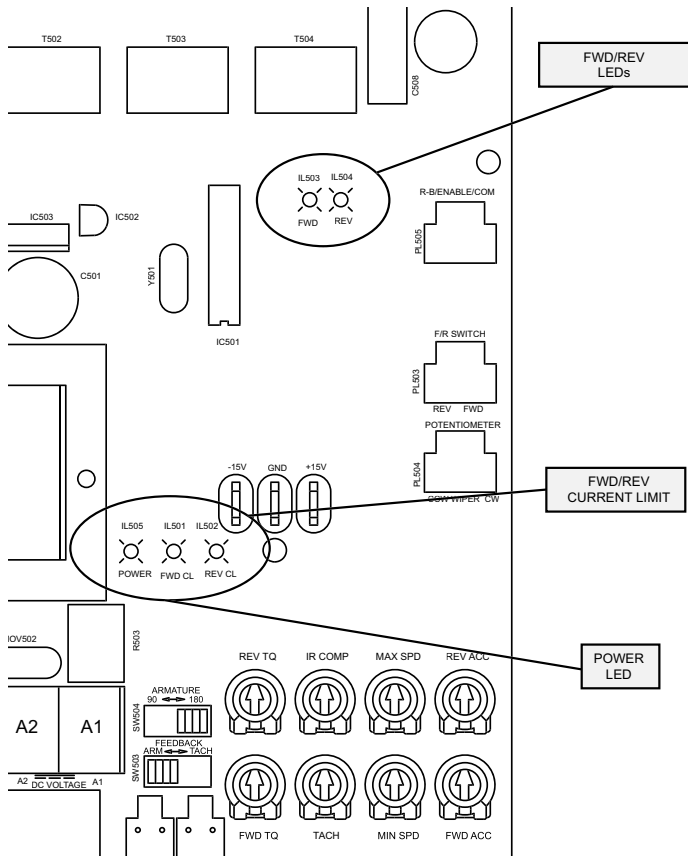
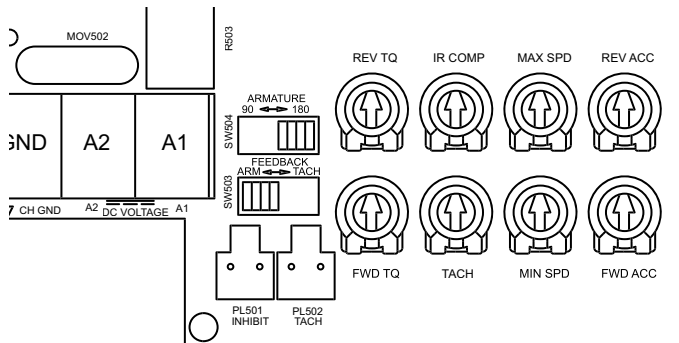

Figure 23. C1RGD Diagnostic LED Location

Calibration

RGD Series drives have eight user adjustable trim pots: MIN SPD, MAX SPD, FWD TQ, REV TQ, IR COMP, FWD ACC, REV ACC, and TACH. Each drive is factory calibrated to its maximum current rating. Readjust the calibration trim pot settings to accommodate lower current rated motors. See page 41 for calibration trim pot layouts.

All adjustments increase with clockwise rotation (CW), and decrease with counter-clockwise rotation (CCW) . Use a non-metallic screwdriver for calibration. Each trim pot is identified on the printed circuit board.



C1RGD Trimpots

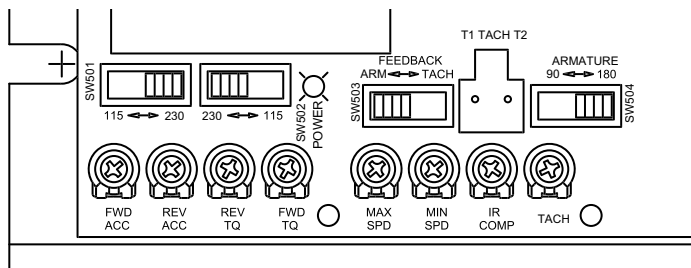

MMRGD Trimpots

Figure 24. Calibration Trimpot Layout

Minimum Speed (MIN SPD)



Note: The minimum speed feature applies only when the drive is operating in unidirectional mode.

Note: Although the C1RGD drive is wired to operate bidirectional mode, the minimum speed feature is still operational.

The MIN SPD setting determines the minimum speed that the motor will rotate. It is factory set to zero speed.

To calibrate, set the speed adjust potentiometer full CCW . Adjust the MIN SPD trimpot clockwise until the motor turns at the desired minimum speed.

Maximum Speed (MAX SPD)

The MAX SPD setting determines the maximum motor speed that the motor will rotate. It is factory set for maximum rated motor speed.

To calibrate, set the speed adjust potentiometer full CW . Adjust the MAX SPD trimpot clockwise until the motor turns at the desired maximum speed.

Forward Torque (FWD TQ)



Warning

Although FORWARD TORQUE (FWD TQ) should be set to 115% of motor nameplate current rating, continuous operation beyond this rating may damage the motor. If you intend to operate beyond the rating, contact your Minarik representative for assistance.

The FWD TQ setting determines the maximum torque for accelerating and driving the motor in the forward direction. It also sets the maximum torque for decelerating the motor in the reverse direction. To recalibrate FWD TQ, refer to the recommended FWD TQ settings in Figure 25, page 50, or use the following procedure:

1. With the power disconnected from the drive, connect a DC ammeter in series with the armature.
2. Set the FWD TQ trimpot to minimum (full CCW).
3. Set the speed adjust potentiometer, voltage input signal, or current input signal for maximum forward speed.
4. Carefully lock the motor armature. Be sure that the motor is firmly mounted.
5. Apply line power. The motor should be stopped.
6. Slowly adjust the FWD TQ trimpot CW until the armature current is 115% of the motor nameplate current rating.
7. Turn the speed adjust potentiometer (or voltage input signal or current input signal to zero, if used) CCW until the motor stops.
8. Disconnect line power.
9. Remove the stall from the motor.

10. Remove the ammeter in series with the motor armature if it is no longer needed.

If the time it takes to accelerate a load is too long due to the forward torque setting, increase the forward torque setting to 130% of rated motor current. The decision to change the forward torque setting must be made after considering the gearbox and drivetrain ratings, duty cycle, and motor characteristics.

Reverse Torque (REV TQ)



Warning

Although REVERSE TORQUE (REV TQ) is set to 115% of motor nameplate current rating, continuous operation beyond that rating may damage the motor. If you intend to operate beyond the rating, contact your Minarik representative for assistance.

The REV TQ setting determines the maximum torque for accelerating and driving the motor in the reverse direction. It also sets the maximum torque for decelerating in the forward direction. To recalibrate REV TQ, refer to the recommended REV TQ settings in Figure 25, page 50, or use the following procedure:

Reverse Torque (cont.)

1. With the power disconnected from the drive, connect a DC ammeter in series with the armature.
2. Set the REV TQ trimpot to minimum (full CCW).
3. Set the speed adjust potentiometer, voltage input signal, or current input signal for maximum reverse speed.
4. Carefully lock the motor armature. Be sure that the motor is firmly mounted.
5. Apply line power. The motor should be stopped.
6. Slowly adjust the REV TQ trimpot CW until the armature current is 115% of motor nameplate current rating.
7. Turn the speed adjust potentiometer (or voltage input signal or current input signal, to zero if used) CCW until the the motor stops.
8. Disconnect line power.
9. Remove the stall from the motor.
10. Remove the ammeter in series with the motor armature if it is no longer needed.

If the time it takes to accelerate a load is too long due to the reverse torque setting, increase the reverse torque setting to 130% of rated motor current. The decision to change the reverse torque setting must be made after considering the gearbox and drivetrain ratings, duty cycle, and motor characteristics.

IR Compensation (IR COMP)

The IR COMP setting (also known as Regulation) determines the degree to which motor speed is held constant as the motor load changes. It is factory set for optimum motor regulation.

Recalibrate the IR COMP setting when using a lower current rated motor. See Figure 25, page 50, for typical IR COMP settings, or recalibrate using the following procedure:

1. Set the IR COMP trimpot to minimum (full CCW).
2. Rotate the speed adjust potentiometer until the motor runs at midspeed without load (for example, adjust to 900 RPM for an 1800 RPM motor). A handheld tachometer may be used to measure motor speed.
3. Load the motor armature to its full load armature current rating. The motor should slow down.
4. While keeping the load on the motor, rotate the IR COMP trimpot until the motor runs at the speed measured in step 2. If the motor oscillates (overcompensation), the IR COMP trimpot may be set too high (CW). Turn the IR COMP trimpot CCW to stabilize the drive.
5. Unload the motor.

Forward Acceleration (FWD ACC)

The FWD ACC setting determines the time the motor takes to ramp to either a higher speed in the forward direction or a lower speed in the reverse direction, within the limits of available torque. The FWD ACC setting is factory set for its fastest forward acceleration time.

Turn the FWD ACC trimpot CW to increase the forward acceleration time, and CCW to decrease the forward acceleration time.

Reverse Acceleration (REV ACC)

The REV ACC setting determines the time the motor takes to ramp to either a higher speed in the reverse direction or a lower speed in the forward direction, within the limits of available torque. The REV ACC setting is factory set for its fastest reverse acceleration time.

Turn the REV ACC trimpot CW to increase the reverse acceleration time, and CCW to decrease the reverse acceleration time.

Tachogenerator (TACH)

NOTE: Calibrate the TACH setting only when a tachogenerator is used.

The TACH setting, like the IR COMP setting, determines the degree to which motor speed is held constant as the motor load changes.

To calibrate the TACH trimpot:

1. Connect the tachogenerator to T1 and T2 on terminal block S0502. The polarity is + for T1 and – for T2 when the motor running in the forward direction.
2. Set switch SW504 to ARM for armature feedback.
3. Set the speed adjust potentiometer full CW. Measure the armature voltage across A1 and A2 using a voltmeter.
4. Set the speed adjust potentiometer to 0 (zero speed).
5. Set SW504 to TACH for tachogenerator feedback.
6. Set the IR COMP trimpot full CCW.
7. Set the TACH trimpot full CW.
8. Set the speed adjust potentiometer full CW.
9. Adjust the TACH trimpot until the armature voltage is the same value as the voltage measured in step 3.

Check that the tachogenerator is properly calibrated. The motor should run at the same set speed when SW504 is set to either armature or tachogenerator feedback

-PCM Only: Signal Adjustment (SIGNAL ADJUST)

The SIGNAL ADJUST trimpot establishes the motor speed obtained in response to the maximum input signal.

To calibrate the SIGNAL ADJUST pot:

1. Adjust the MAX SPD trimpot full CW.
2. Apply the maximum signal.
3. Adjust the SIGNAL ADJUST trimpot until the motor runs at the desired speed.

To Switch directions, short TB501-4, DIR, to TB501-3, COM. This inverts the signal to the MMRGD. Use a relay cont act, switch or jumper to change directions.

115 VAC INPUT

1/2 HP
90 VDC
1750 RPM
5 ADC



IR COMP



FWD TQ



REV TQ

3/4 HP
90 VDC
1750 RPM
7.6 ADC



IR COMP



FWD TQ



REV TQ

1 HP
90 VDC
1750 RPM
10 ADC



IR COMP



FWD TQ



REV TQ

230 VAC INPUT

3/4 HP
180 VDC
1750 RPM
3.8 ADC



IR COMP



FWD TQ



REV TQ

1 HP
180 VDC
1750 RPM
5 ADC



IR COMP



FWD TQ



REV TQ

2 HP
180 VDC
1750 RPM
10 ADC



IR COMP



FWD TQ



REV TQ

Figure 25. Recommended IR COMP, REVERSE TORQUE and FORWARD TORQUE Settings

Application Notes

Connections to DLC600

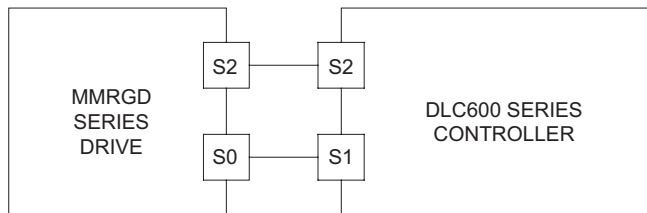

Figure 26. MMRGD Connections to DLC600

Optional speed adjust potentiometer connections to MMRGD series drives

Use a single-pole, two-position switch with a single speed-adjust potentiometer to plug reverse the motor (Figure 27).

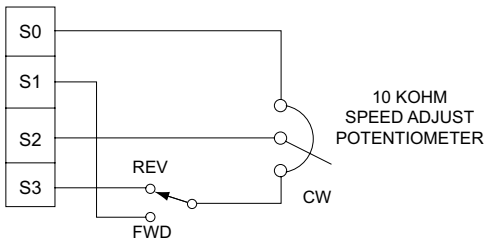

Figure 27. Forward-Reverse Switch

Use a single-pole, three-position switch with a single speed-adjust potentiometer to stop a motor between reversals (Figure 28). Set the switch to the center position to decelerate the motor to a stop.

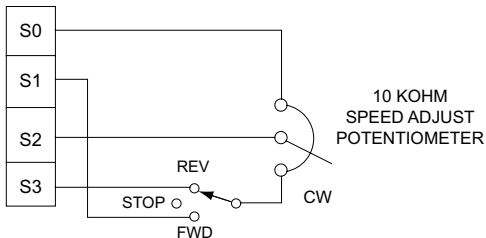

Figure 28. Forward-Stop-Reverse Switch

Independent Adjustable Speeds (Forward Direction Only)

Connect two speed-adjust potentiometers with a single-pole, two-position switch (with a total parallel resistance of 10K ohms) to select between two independent speeds in the forward direction as shown (Figure 29). The speed-adjust potentiometers can be mounted at two separate operating stations.

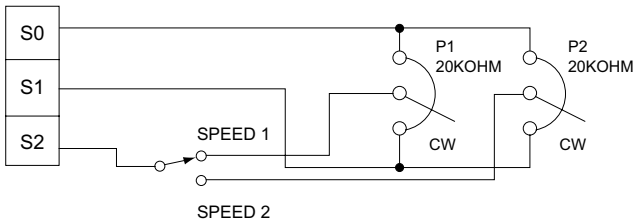

Figure 29. Independent Adjustable Speeds (Forward Direction)

Independent Forward and Reverse Speeds

Connect two speed-adjust potentiometers as shown in Figure 30 to select between independent forward and reverse speeds.

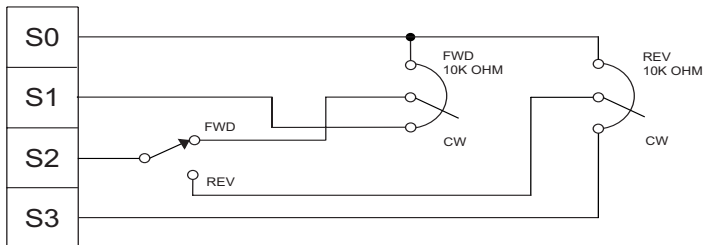

Figure 30. Independent Forward and Reverse Speeds

Independent Forward and Reverse Speeds With FWD-STOP-REV Switch

Use a single-pole, three-position switch to stop the motor when the switch is in the center position (Figure 31).

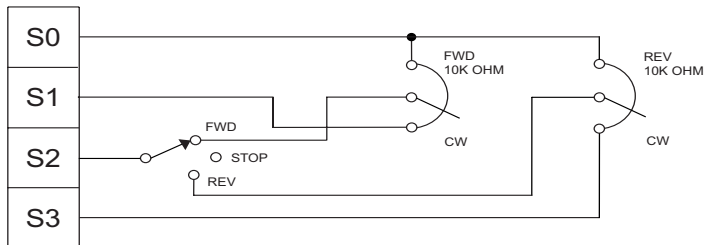

Figure 31. Independent Forward and Reverse Speeds with a Forward-Stop-Reverse Switch

Troubleshooting



Warning

Dangerous voltages exist on the drive when it is powered.
When possible, disconnect the drive while troubleshooting.
High voltages can cause serious or fatal injury.

Before troubleshooting

Perform the following steps before starting any procedure in this section:

- Disconnect AC line voltage from the drive.
- Check the drive closely for damaged components.
- Check that no conductive or other foreign material has become lodged on the printed circuit board.
- Verify that every connection is correct and in good condition.
- Verify that there are no short circuits or grounded connections.
- Check that the drive's rated armature outputs are consistent with the motor ratings.
- Check that the line frequency switch is properly set.

For additional assistance, contact your Minarik representative, or the factory direct at:

Tel.: 1-800-MINARIK (646-2745) or

Fax: 1-800-394-6334

Problem	Possible Causes	Suggested Solutions
Line fuse blows.	<ol style="list-style-type: none"> 1. Line fuse is the wrong size. 2. Motor cable or armature is shorted to ground. 3. Nuisance tripping caused by a combination of ambient conditions and high-current spikes (i.e. reversing). 	<ol style="list-style-type: none"> 1. Check that the line fuse is correct for the motor size. 2. Check motor cable and armature for shorts. 3. Decrease FWD TQ and REV TQ settings, or resize motor and drive for actual load demand, or check for incorrectly aligned mechanical components or "jams".
Line fuse does not blow, but the motor does not run	<ol style="list-style-type: none"> 1. Speed adjust pot or voltage reference is set to zero speed. 2. Speed adjust pot or voltage reference is not connected to drive input properly; connections are open. 3. INHIBIT terminals are jumpered. 4. S2 is shorted to S0. 5. Drive is in current limit. 	<ol style="list-style-type: none"> 1. Increase the speed adjust pot setting or voltage reference. 2. Check connections to input. Verify that connections are not open. 3. Remove jumper from the INHIBIT terminals. 4. Remove short. 5. Verify that motor is not jammed. Increase FWD TQ or REV TQ setting if they are set too low.

Problem	Possible Causes	Suggested Solutions
Line fuse does not blow, but the motor does not run. (cont.)	<ol style="list-style-type: none"> 6. Drive is not receiving AC line voltage. 7. Motor is not connected. 	<ol style="list-style-type: none"> 6. Apply AC line voltage to L1 and L2. 7. Connect motor to A1 and A2.
Motor runs too fast.	<ol style="list-style-type: none"> 1. MAX SPD not calibrated. 	<ol style="list-style-type: none"> 1. Calibrate MAX SPD.
Motor will not reach the desired speed.	<ol style="list-style-type: none"> 1. MAX SPD setting is too low. 2. IR COMP setting is too low. 3. Motor is overloaded. 	<ol style="list-style-type: none"> 1. Increase MAX SPD setting. 2. Increase IR COMP setting. 3. Check motor load. Resize the motor and drive if necessary.
Motor pulsates or surges under load.	<ol style="list-style-type: none"> 1. IR COMP is set too high. 2. Motor bouncing in and out of current limit. 	<ol style="list-style-type: none"> 1. Adjust the IR COMP setting slightly CCW until the motor speed stabilizes. 2. Make sure motor is not undersized for load; adjust FWD TQ and REV TQ trimpots CW.

Replacement Parts

Replacement parts are available from Minarik Corporation and its distributors for this drive series.

Table 2. Replacement Parts

Model No.	Symbol	Description	Minarik P/N
MMRGD03-D230AC	R503	0.1W, 5 W Resistor	032-0100
	SCR501-508	800 V, 25 A SCR	072-0042
	T501	DST-436 115/230: 36VCT	230-0072
		10KW Potentiometer Kit Chassis	202-0082 222-0191
MMRGD10-D230AC	R503	0.01W, 5 W Resistor	032-0129
	SCR501-508	800 V, 25 A SCR	072-0042
	T501	DST-436 115/230: 36VCT	230-0072
		10KW Potentiometer Kit Chassis	202-0082 222-0191
MMRGD03-D230AC-PCM	Same as MMRGD03-D230AC		
MMRGD10-D230AC-PCM	Same as MMRGD10-D230AC		
C1RGD03-D230AC	Same as MMRGD03-D230AC except		
	T505	DST-436 115/230:36VCT	230-0072
		C1RGD Pot Assembly Chassis	201-0171 223-0170
C1RGD10-D230AC	Same as MMRGD10-D230AC		
	T505	DST-436 115/230:36VCT	230-0072
		C1RGD Pot Assembly Chassis	201-0171 223-0170
Fuse Kits		3-8A Fuse Kit (with 1/8A pico fuse)	050-0069
		5-20A Fuse Kit (with 1/8A pico fuse)	050-0073
		1/8A Pico Fuse	050-0064
Inhibit Plugs		Inhibit Plug with 18 in. (46 cm) wires	201-0024
		Inhibit Plug with 36 in. (91 cm) wires	201-0079

Notes

Notes

Notes

Unconditional Warranty

A. Warranty

Minarik Corporation (referred to as "the Corporation") warrants that its products will be free from defects in workmanship and material for twelve (12) months or 3,000 hours, whichever comes first, from date of manufacture thereof. Within this warranty period, the Corporation will repair or replace, at its sole discretion, such products that are returned to Minarik Corporation, 901 East Thompson Avenue, Glendale, CA 91201-2011 USA.

This warranty applies only to standard catalog products, and does not apply to specials. Any returns for special controls will be evaluated on a case-by-case basis. The Corporation is not responsible for removal, installation, or any other incidental expenses incurred in shipping the product to and from the repair point.

B. Disclaimer

The provisions of Paragraph A are the Corporation's sole obligation and exclude all other warranties of merchantability for use, express or implied. The Corporation further disclaims any responsibility whatsoever to the customer or to any other person for injury to the person or damage or loss of property of value caused by any product that has been subject to misuse, negligence, or accident, or misapplied or modified by unauthorized persons or improperly installed.

C. Limitations of Liability

In the event of any claim for breach of any of the Corporation's obligations, whether express or implied, and particularly of any other claim or breach of warranty contained in Paragraph A, or of any other warranties, express or implied, or claim of liability that might, despite Paragraph B, be decided against the Corporation by lawful authority, the Corporation shall under no circumstances be liable for any consequential damages, losses, or expense arising in connection with the use of, or inability to use, the Corporation's product for any purpose whatsoever.

An adjustment made under warranty does not void the warranty, nor does it imply an extension of the original 12-month warranty period. Products serviced and/or parts replaced on a no-charge basis during the warranty period carry the unexpired portion of the original warranty only.

If for any reason any of the foregoing provisions shall be ineffective, the Corporation's liability for damages arising out of its manufacture or sale of equipment, or use thereof, whether such liability is based on warranty, contract, negligence, strict liability in tort, or otherwise, shall not in any event exceed the full purchase price of such equipment.

Any action against the Corporation based upon any liability or obligation arising hereunder or under any law applicable to the sale of equipment or the use thereof, must be commenced within one year after the cause of such action arises.

Other products from Minarik Corporation:



DLC600



C1RGD



VFD04-D230AC-PCM



RG60U

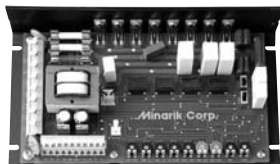

RG500UA

